



A6Z OPERATING MANUAL

TABLE OF CONTENTS

Introduction.....	p. 2
Features	p. 2
Description.....	p. 3
Theory of Operation	p. 3
Installation	p. 4
Electrical Connections	p. 5
Options.....	p. 6
Warranty.....	p. 6
Specifications	p. 7
Troubleshooting	p. 8
Ordering Codes	p. 9
Wiring Diagrams	p. 10 - 21
Dimensional drawings	p. 22 - 30



Avatar Instruments, Inc.
Phone: (610) 543-5155

577 Abbott Drive
Fax: (610) 543-5255

Broomall, PA 19008
www.scrpower.com

INTRODUCTION

Congratulations on your purchase of an Avatar A6Z series power control. This manual was designed to assist you in installing, operating and maintaining your new power control in a safe manner. Upon reading and following the instructions in this manual, you will be rewarded many years of trouble free service from your new A6Z. If reading manuals is not for you, it is essential that you at least read the captions followed by the safety warnings; they are located through out the manual and are very easy to identify.



indicates important installation, operating, servicing instructions



indicates dangerous voltage present and risk of electric shock

FEATURES

- UL 508 listed, CE pending
- compact and light weight
- 100 % solid state circuitry
- over-rated SCR power modules
- over-sized heat sink
- full power ratings up to 50°C (122°F) ambient temperature
- optically isolated 4-20 mA input standard
- variable time base provides high resolution control
- electrically isolated chassis and heat sinks to 600 Amps
- gold alodined chassis and heat sink
- I²T fusing and MOV protection on all power SCR's
- SanRex, SemiKron, International Rectifier and Fairchild semiconductors
- double sided FR4 VO-94 rated glass epoxy PCB's

DESCRIPTION

The A6Z is a proportional, zero voltage switched, three leg controlled, three phase power controller capable of delivering 0-99% of the applied line voltage to directly connected electric heaters. It will not work on tungsten lamps, transformers or motors. This is accomplished by time proportionally switching SCR's on and off. Modular construction allows for simple and solderless field serviceability. There are four field replaceable items:

- printed circuit board
- fuses
- SCR packages
- MOV's (metal oxide varistors)

THEORY OF OPERATION

The standard input signal (4-20mA) is applied to the blue input terminal block, processed and fed to optical couplers. The output of each opto coupler controls its respective SCR. An I²T fuse connected in series with the input provides over current protection in the event of external wiring shorts, or too large of a heater load. Additionally, a MOV (metal oxide varistor) is connected in parallel with each SCR, providing voltage spike protection to the controller.

Zero voltage switching controls proportionally turn on and off each full cycle of the power line. By varying the number of AC power line cycles, the SCR provides power to the heaters. With a variable time base, the optimum number of cycles turned on/off is achieved. This method produces less RFI line noise than phase angle fired SCRs. Power factor is 100%, while harmonic distortion is limited. Charts below, left and center show 25% power output using variable time based zero voltage switching. The chart on the right shows 50% output.

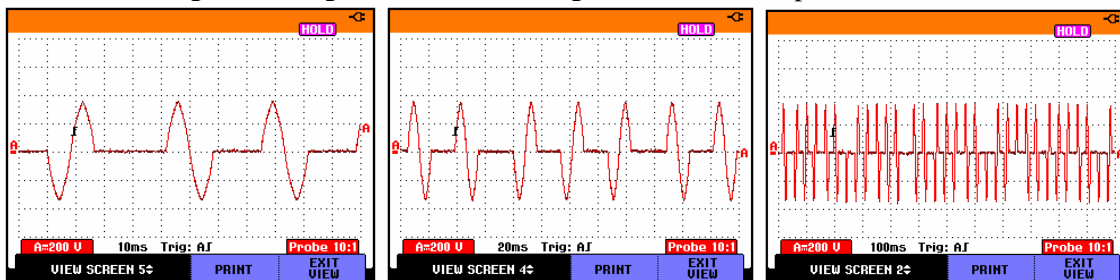

Avatar Instruments variable time base SCR firing. Note how half cycles can be turned on and off providing 0.08 second resolution on 60Hz power lines.

INSTALLATION



WARNING: FIRE HAZARD!! Even the best electronic components CAN FAIL SHORTED, KEEPING FULL POWER ON! Provide a completely SEPARATE (redundant) OVER TEMPERATURE SHUTDOWN MEANS to switch power off if safe temperature is exceeded.



WARNING: HIGH VOLTAGE!! This control must be installed in a GROUNDED enclosure. Provide a safety interlock on door to remove power before gaining access to device.



This controller must be installed by a qualified electrician in accordance with any and all local and national electric codes including NEC and any other applicable codes.

First things first, do you have the proper controller for your application? Check the Avatar serial tag and verify the correct voltage/ ampere ratings and input control signal for your application.

After verifying you have the proper controller, the next most important item is adequate cooling/ ventilation. All Avatar power controllers are rated to deliver full power to their respective load(s) at an ambient temperature not to exceed 50°C. Use this formula to calculate the minimum size enclosure required.

number of SCR's X 1.2 VOLTS X MAXIMUM HEATER CURRENT = TOTAL WATTS DISSIPATED

example: 3 x 1.2 x 60 amps = 216 watts that the power controller has to dissipate

Heat is the worst enemy to any electrical device, including power controllers. Orient heat sink fins and chassis channel in a vertical position, providing adequate air flow above and below unit. The cooler the unit operates, the longer it will provide seamless, reliable service.

The dryer and cleaner, the better! Over time, a combination of moisture and contaminants will lead to failure due to corrosion and insulation breakdown (arcing and sparking). If the controller absolutely must be installed in a harsh and corrosive environment, it is recommended that an air conditioned NEMA 4X or similar type of environmentally sealing enclosure be used during installation.

ELECTRICAL CONNECTIONS



Again, this work must be performed by a qualified electrician and in accordance with any and all local and national codes that may apply. Please refer to the wiring diagrams (pgs. 10 - 21).



To reduce the risk of electrocution, **TURN ALL POWER OFF** to wires that will be connected to the power control before making any connections. The A6Z controller is installed in a metal enclosure for protection against electrocution. 1200 amp controller heat sinks **are on line voltage!!**

AC POWER INPUT:

Power input (AC MAINS) is connected to lugs labeled "LINE 1", "LINE 2" and "LINE 3"(see fig. 1 for correct wire size and torque specs.)

LOAD CONNECTION:

Load connections are equally simple; connect the load/ heater to lugs labeled "HTR 1", "HTR 2"and "HTR 3" (see fig. 1 for correct wire size and torque specs).

NOTE: *The A6Z is capable of controlling open delta or 4 wire "wye" connected loads.*

The A6Z is capable of driving unbalanced loads, but it is highly recommended to equally **BALANCE LOADS BETWEEN ALL THREE PHASES** to provide consistent tracking between all three phases. The A6Z can also be used to fire inside delta wired loads, or be used to fire into three (3) separate single phase loads at the same time.

Check heater resistance to insure heater current will not exceed fuse ratings. Controllers DO NOT blow fuses - excess heater current does. Check for heater wiring shorts, shorted load connections will instantly blow expensive fuses.

INPUT CONTROL SIGNAL:

Connect the control signal to the blue terminal block labeled "4-20mA INPUT" observing proper polarity (positive to "+" and negative to "-").

THERMOSTAT for FAN FAILURE:

On all Avatar SCR Controls 150 Amps and above, fans are used to cool the SCR heat sinks. Avatar mounts a Snap-disc thermostat to the heat sink. If the fan fails, air is blocked or a safe ambient temperature is exceeded, the thermostat will activate. This thermostat can be used to break 4-20mA input signal, trigger alarms or shut down a power contactor. See wiring diagram for thermostat wiring (pgs. 19, 20 and 21).

OPTIONS

"R" RELAY OPTION: For 10-32 VDC or 120VAC Signal Input to turn A6Z into On/Off controller, use "R" relay option. Call out as **"-R32"** or **"-R120"**

"R/S" SLAVE OPTION: To slave A6Z to another SCR control, use RELAY/SLAVE Option. Call Out as "-RS" to part number. Also inform Avatar of the line/trigger voltage you intend to use.

For manual control use Avatar model **MAP**. Isolated Potentiometer 4-20mA signal card.

For LINEAR 0-5 or 0-10 VDC Analog Signal use Avatar MAI milliamp interface card.

MAI-05V takes a 0-5VDC signal input and outputs 4-20mA.

MAI-10V takes a 0-10VDC signal input and outputs 4-20mA.

WARRANTY

All Avatar Instruments products carry a full *five year*, warranty from date of purchase, parts and labor warranty against component failure and defects in workmanship. In the event your controller fails to perform properly, **contact Avatar to obtain a return authorization number**. Controllers sent to Avatar for warranty service that have no apparent defect will be treated as a standard repair and a \$50.00 charge will be applied. Avatar will repair or replace any unit that failed due to defective parts or assembly. This warranty DOES NOT cover damage due to shipping, abuse, misapplication or operation beyond specified rating. Furthermore, fuses and improperly fused SCR's are NOT COVERED by this warranty. Avatar is not responsible for any subsequent or other damage experienced in use of this device.

SPECIFICATIONS

INPUT VOLTAGE:	see model description
OUTPUT VOLTAGE:	0-99% of input voltage
CURRENT CAPACITY:	see model description
CONTROL SIGNAL:	4-20mA @ 10 volts DC
INPUT IMPEDANCE:	500 ohms
POWER DISSIPATION (Watts):	3.6 x maximum current
COOLING: 30-80 amp	convection
100-1200 amp.....	fan(s) 120VAC
THERMOSTAT:	190°F (fan cooled units only)
DIMENSIONS:	see dimensional drawings
WEIGHT:	NET SHIPPING
30 amp.....	7 lb 9 lbs.
40-80 amp.....	14 lbs. 15 lbs.
100 amp	18 lbs. 21lbs.
150 amp compact.....	30 lbs. 45 lbs.
200-350 amp	50 lbs. 65 lbs.
600 amp.....	60 lbs. 75 lbs.
1200 amp.....	231 lbs. 300 lbs.

Wire Gauge and Torque Specifications for 90°C Temp Wire			
Power Control Maximum Current Rating/ Circuit	Copper Wire Only MINIMUM AWG	Wire Lug Torque Spec. (lbs./in.)	Lug Size
30A	10AWG	35	10 AWG
40A	8AWG	40	1/0 - 14
60A	6AWG	45	1/0 - 14
80A	4AWG	45	1/0 - 14
100A	3AWG	50	1/0 - 14
150A	1AWG	180	250MCM - 6
200A	3/0 AWG	250	250MCM - 6
225A	3/0 AWG	250	250MCM - 6
250A	4/0 AWG	250	250MCM - 6
350A	TWO: 4/0 AWG	250	TWO: 250MCM-6
600A	TWO: MCM 350	325	TWO: 600MCM-2
1200A	FOUR: MCM 350	375	FOUR: 600MCM-2

fig. 1

TROUBLESHOOTING

SYMPTOM	POSSIBLE CAUSE	POSSIBLE SOLUTION
Heaters do not heat up	no power to A6Z	verify correct input voltage between the three "LINE" lugs on A6Z.
	blown fuses in A6Z	check for heater and wiring shorts, check current rating on heaters and replace fuses as necessary. Will blow fuses on tungsten lamps or transformers.
	no control signal to A6Z	verify 4-20mA signal is hooked up correctly on the source and A6Z; positive to "+" and negative to "-"
	defective heaters	check for output voltage between the three "HTR" lugs. If voltage is present, check wiring to the heaters and the actual heaters.
	defective source	measure the output of the source (temperature controller, PLC, etc.) by placing a milliamp meter in SERIES with the signal wires.
Heaters are on full all the time	incorrect source signal	verify 4-20mA signal varies from 4-20mA.
	shorted SCR's in controller	with power applied, measure voltage drop across "LINE 1" and "HTR 1", if voltage reading is less than one volt, the associated SCR is bad. Perform same test on "LINE 2" to "HTR 2", and "LINE 3" to "HTR 3".
Process will not stabilize, control signal oscillates	incorrect temperature control tuning, slow temperature sensing	re-tune temperature control, use faster sensor, place sensor closer to process.

A6Z SERIES SCR POWER CONTROLLERS

ORDERING CODES

A6Z - _____ - _____ - _____ - _____
Voltage Amperes Options Options

VOLTAGE DESIGNATIONS

- (12) 120 VAC 50/60Hz
- (24) 208-240 VAC 50/60Hz
- (27) 277 VAC 50/60Hz
- (38) 380 VAC 50/60Hz
- (48) 480 VAC 50/60Hz
- (57) 575 VAC 50/60Hz
- (60) 600 VAC 50/60Hz

LOAD IN AMPS:

- 30, 40, 60, 80, 100, 150
- 200, 225, 250, 350, 600, 1200

OPTIONS:

R Option

- 10-32 VDC on-off command signal (-R32)
- 120 VAC on-off command signal (-R120)

Example: A6Z-48-60 is a zero voltage switched, three phase, 480VAC, 60 Ampere SCR.

A6Z WIRING DIAGRAM (3 WIRE 3 LEG DELTA LOAD)

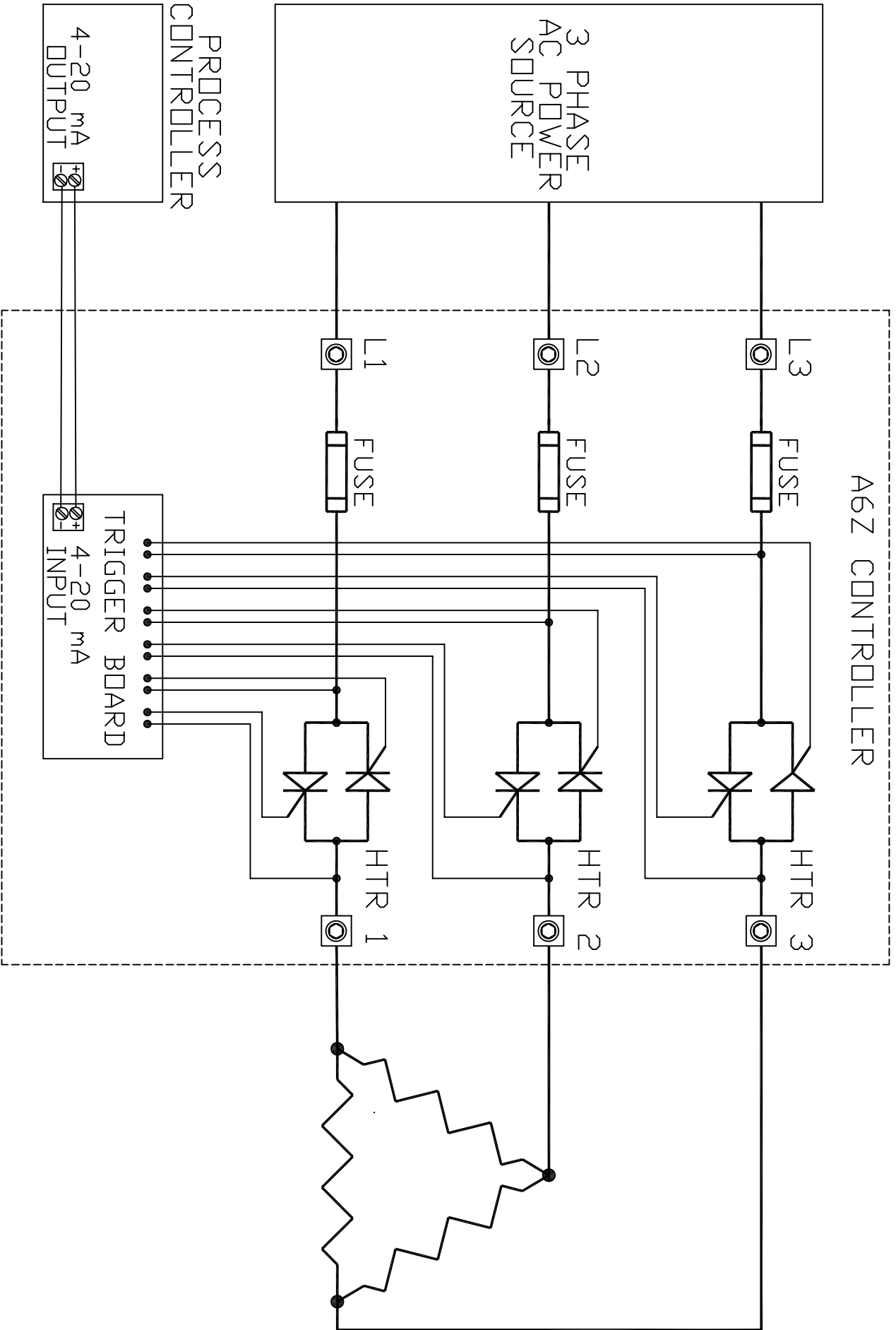

A6Z WIRING DIAGRAM (3 WIRE 3 LEG WYE LOAD)

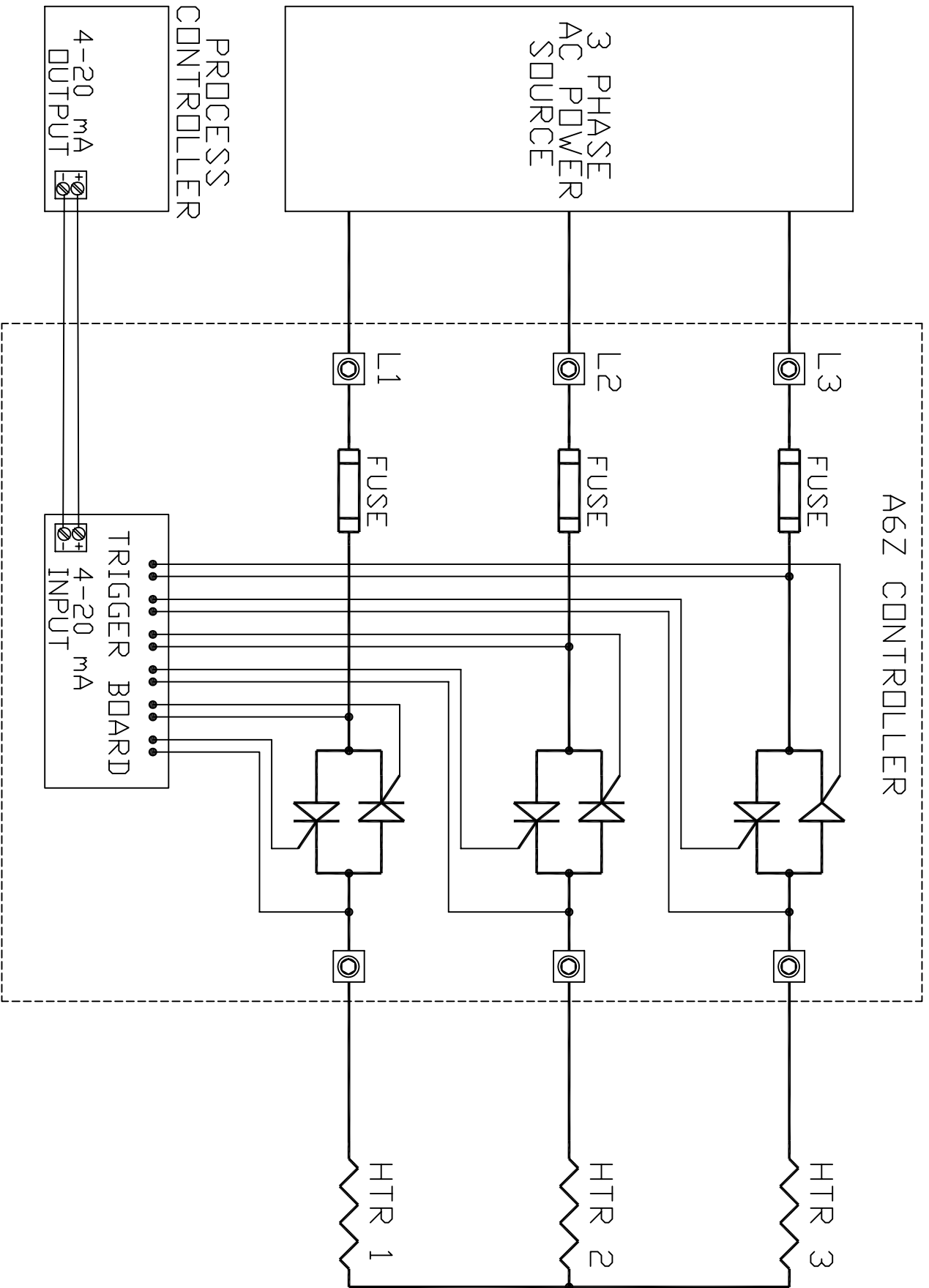

**A6Z WIRING DIAGRAM "R32" OPTION
10-32VDC COMMAND INPUT SIGNAL
(3 WIRE 3 LEG DELTA LOAD)**

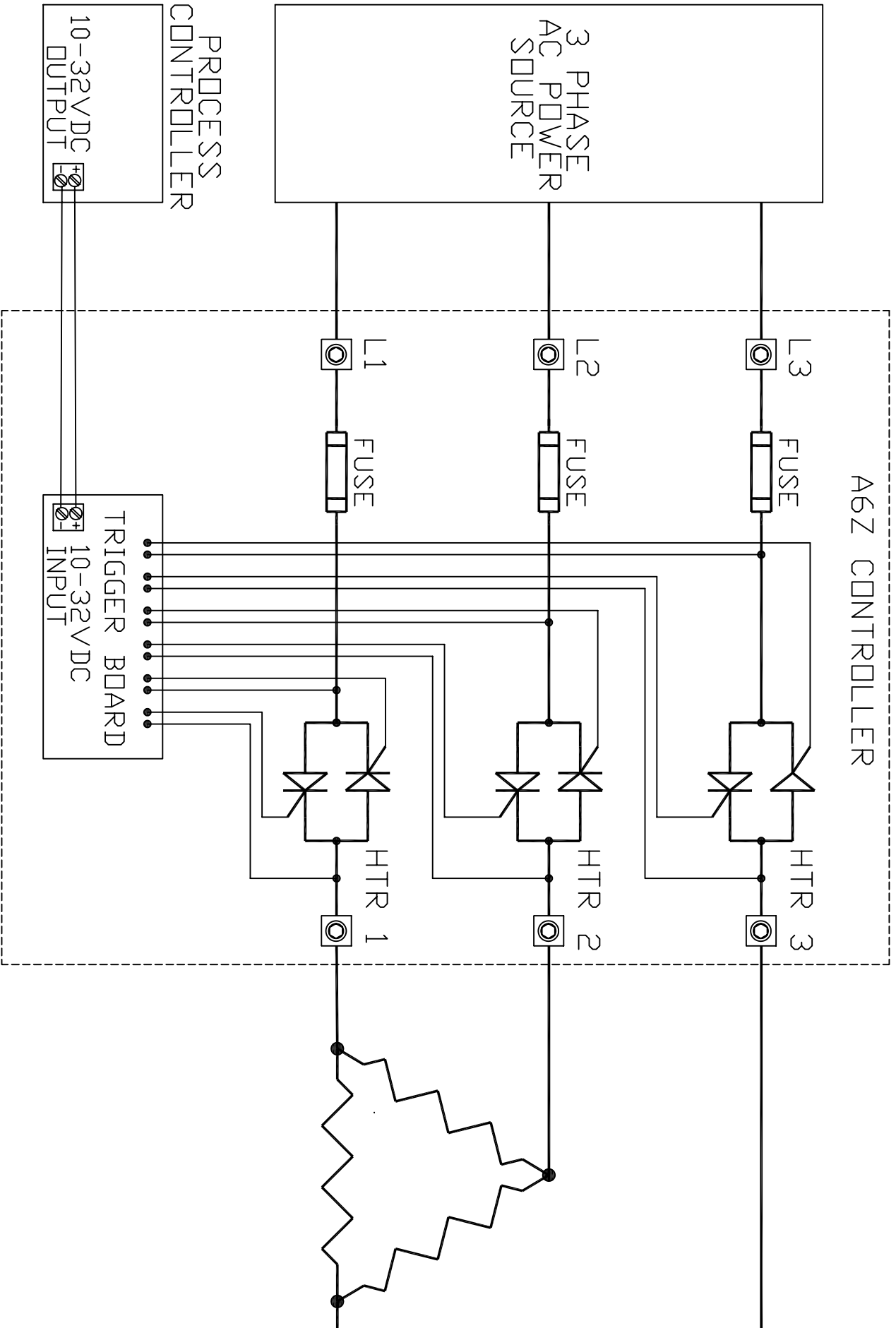

**A6Z WIRING DIAGRAM "R32" OPTION
10-32VDC COMMAND INPUT SIGNAL
(3 WIRE 3 LEG WYE LOAD)**

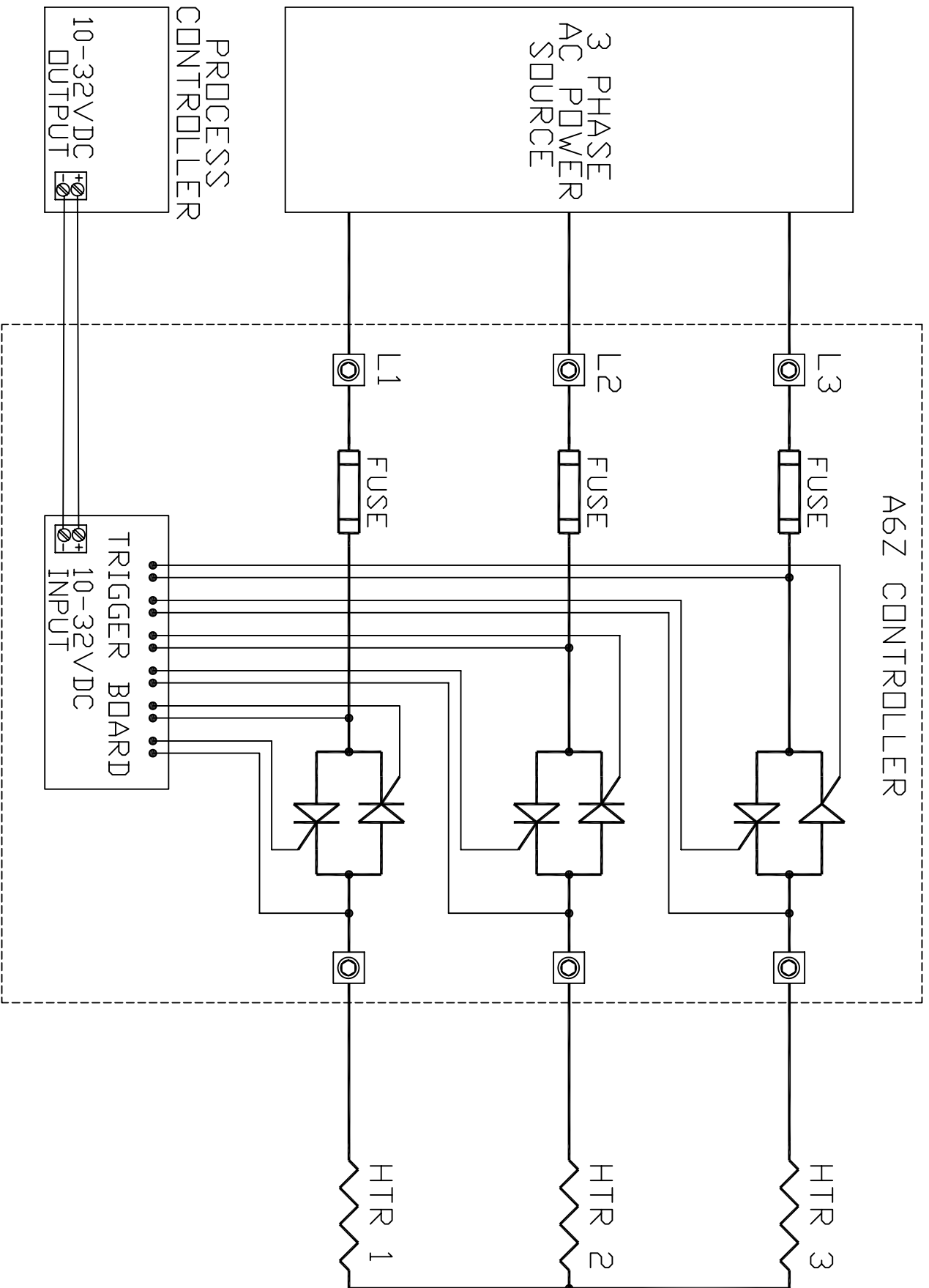

**A6Z WIRING DIAGRAM "R120" OPTION
120VAC COMMAND INPUT SIGNAL
(3 WIRE 3 LEG DELTA LOAD)**

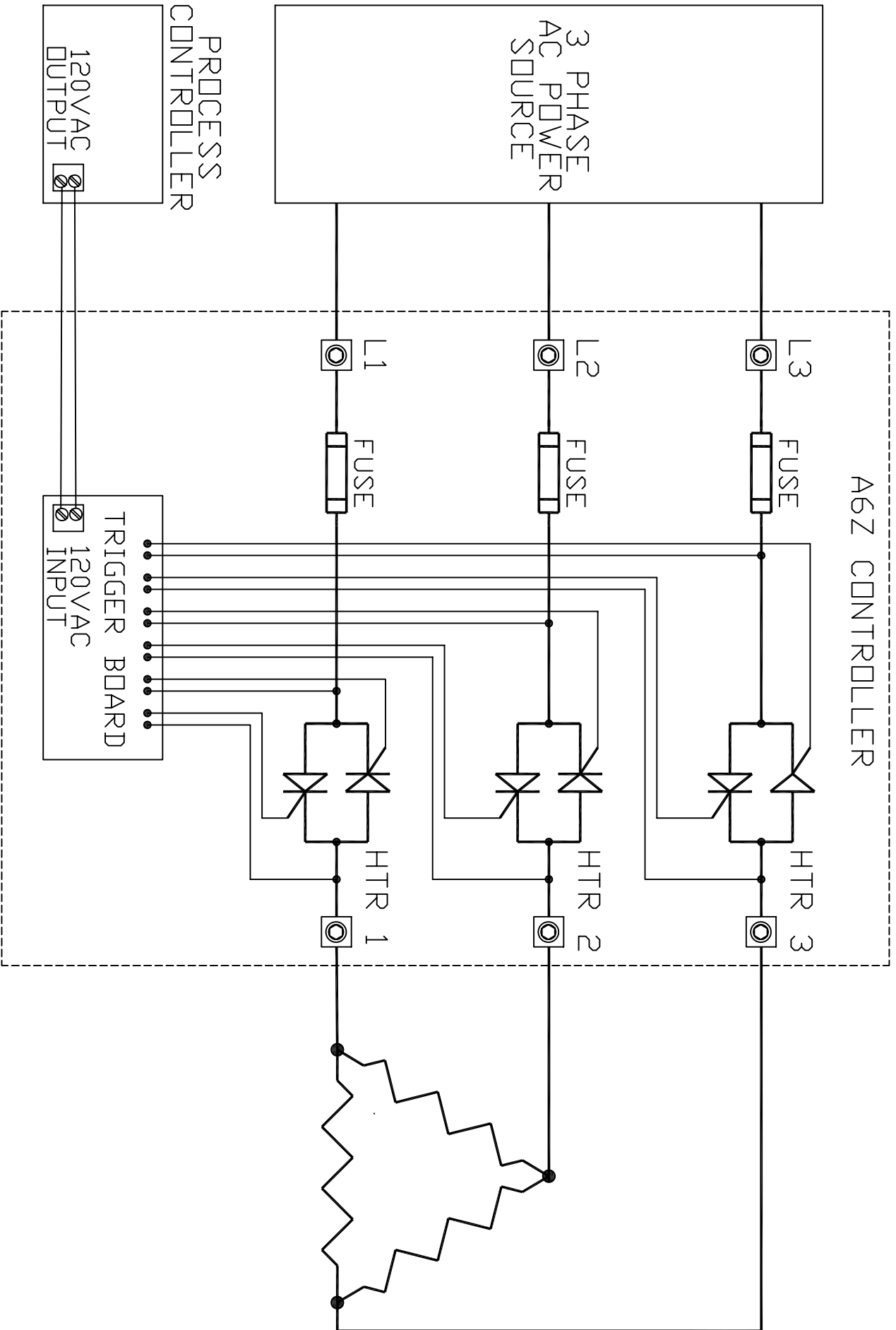

**A6Z WIRING DIAGRAM "R120" OPTION
120VAC COMMAND INPUT SIGNAL
(3 WIRE 3 LEG WYE LOAD)**

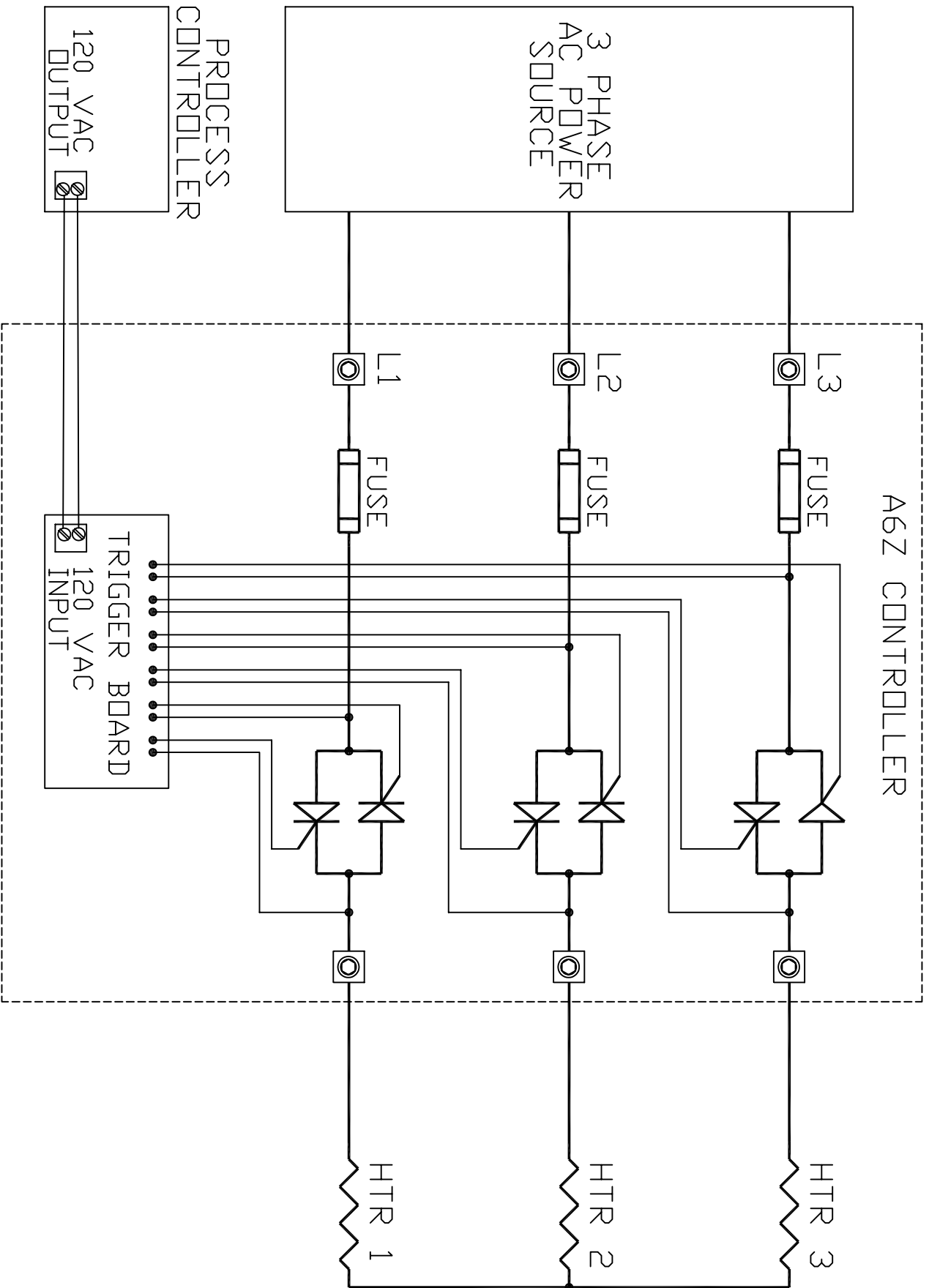

A6Z WIRING DIAGRAM (4 WIRE 3 LEG WYE LOAD)

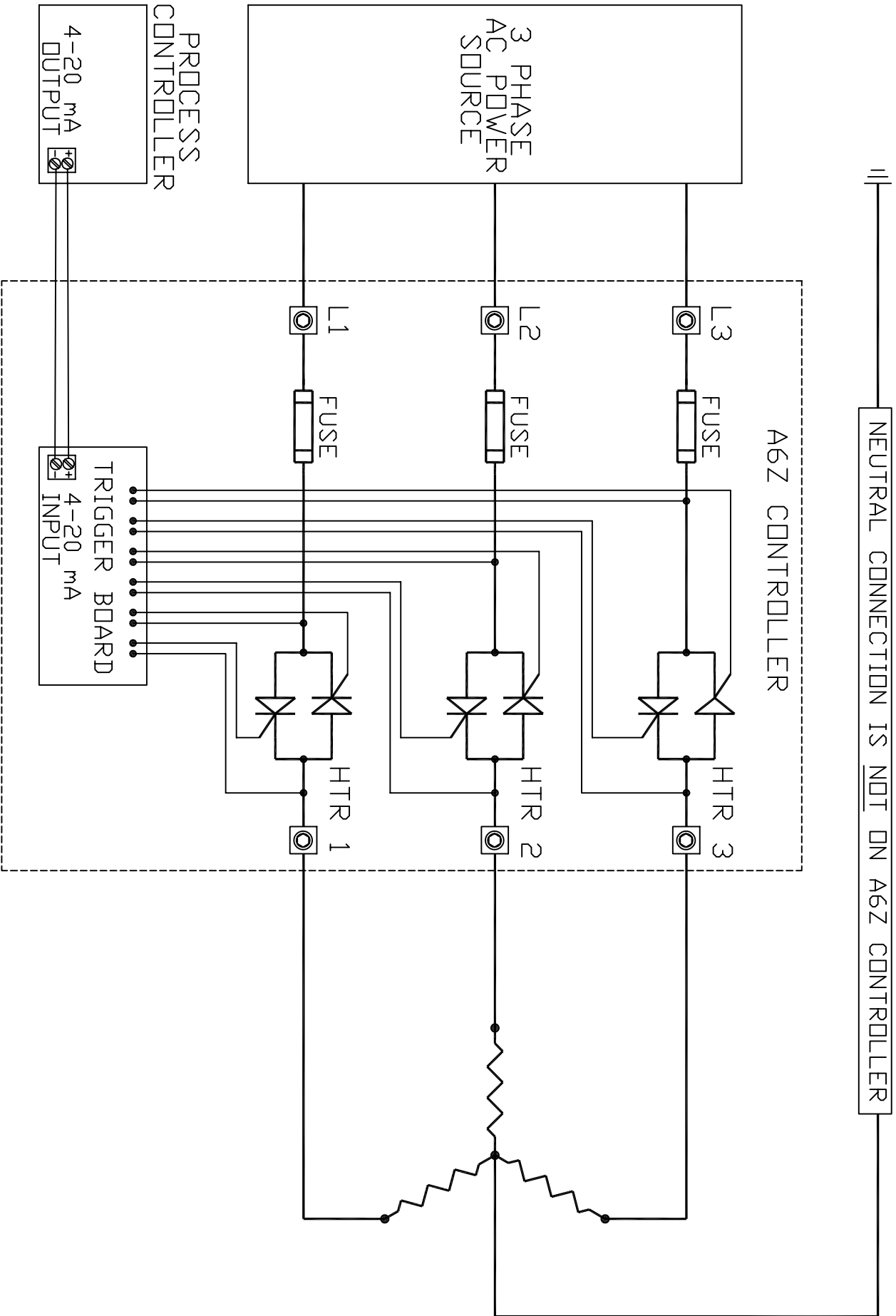

NEUTRAL CONNECTION IS NOT ON A6Z CONTROLLER

**A6Z WIRING DIAGRAM "R32" OPTION
 10-32VDC COMMAND SIGNAL
 (4 WIRE 3 LEG WYE LOAD)**

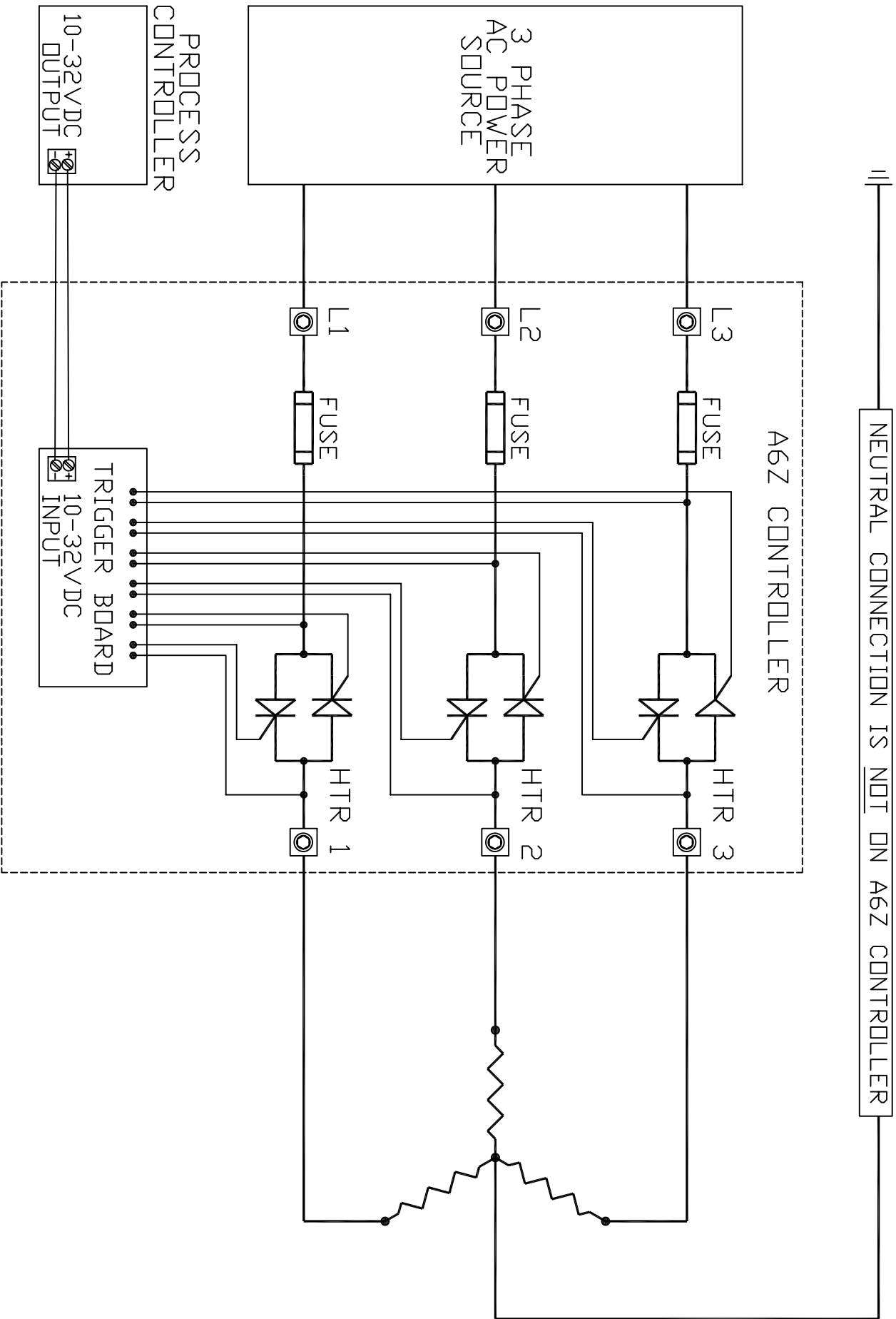

**A6Z WIRING DIAGRAM "R120" OPTION
 120VAC COMMAND INPUT SIGNAL
 (4 WIRE 3 LEG WYE LOAD)**

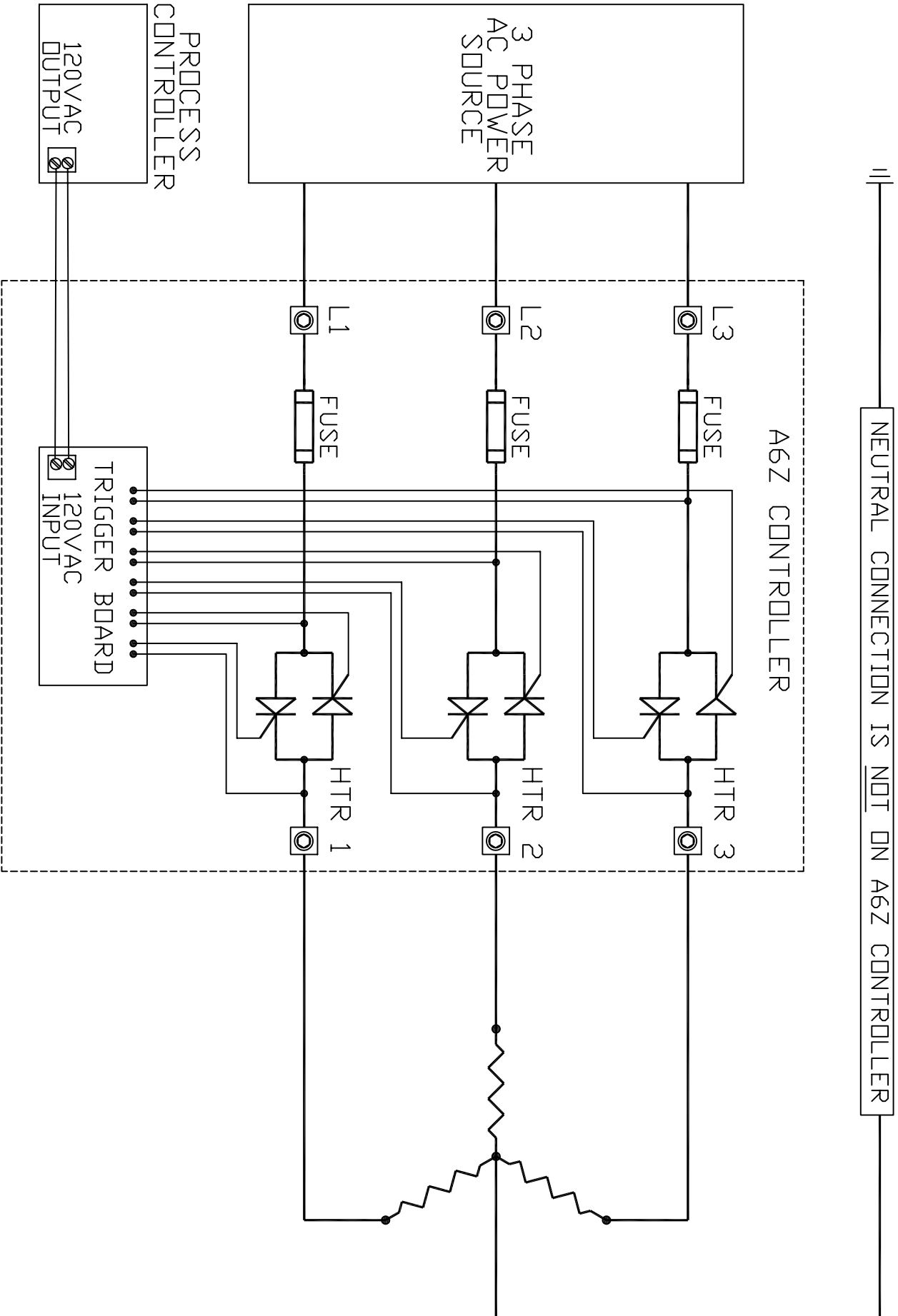

OVERTEMPERATURE THERMOSTAT WIRING DIAGRAMS

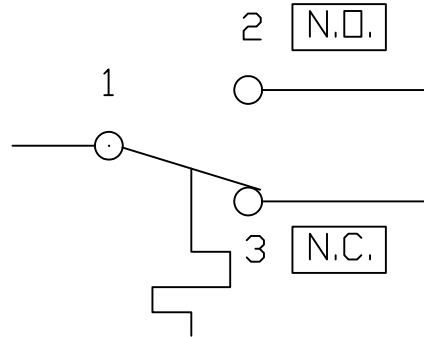
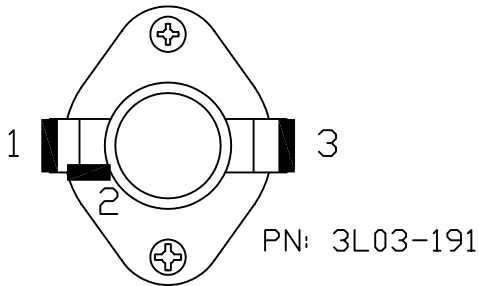

CONTACT RATINGS

1 & 2:
5.8A 120VAC
2.9A/240VAC

1 & 3:
10A/120VAC
5A/240VAC

OPEN: 190F
CLOSE: 170F

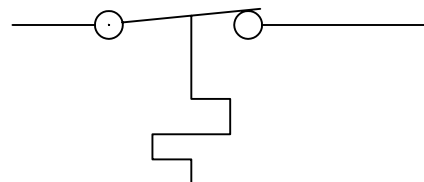
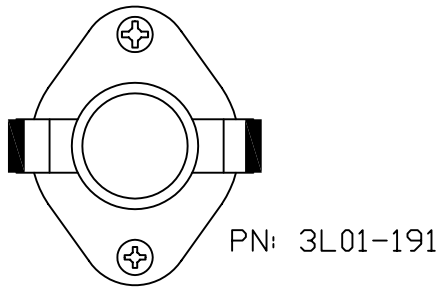

CONTACT RATING:
10A/120VAC
5A/240VAC

OPEN: 190F
CLOSE: 170F

FAN WIRING DIAGRAMS

100 thru 600 AMPS

TERMINAL TYPE 6.9

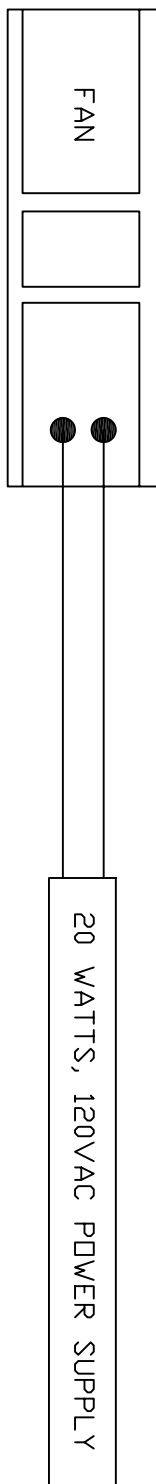

WARNING!
Fans MUST be ON when SCR power controller is on!
Power to fans must be applied before or coinciding with the turn on of line voltage to the SCR power controller. *Failure to do so will damage SCRs and other components.*

TERMINAL BLOCK

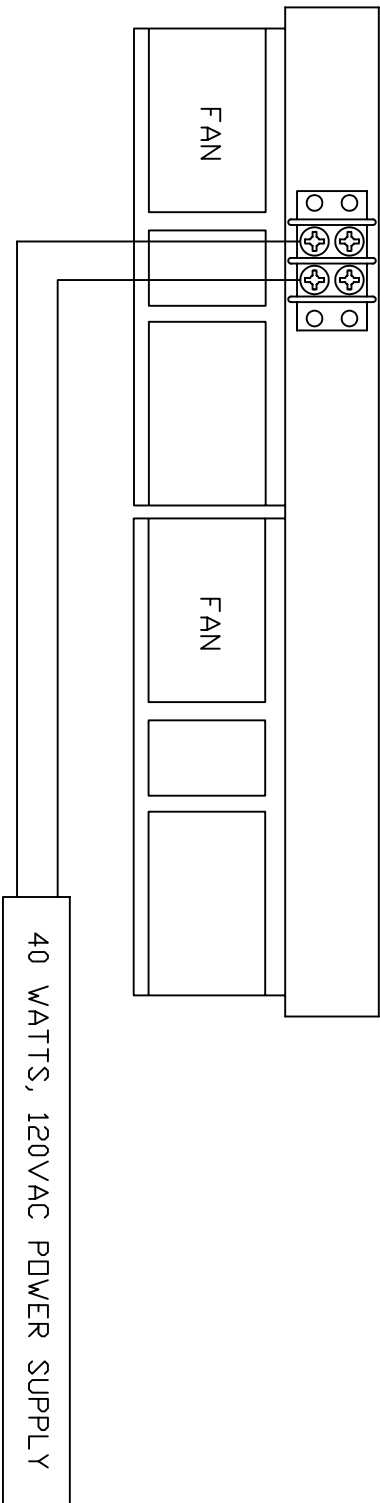

TERMINAL BLOCK

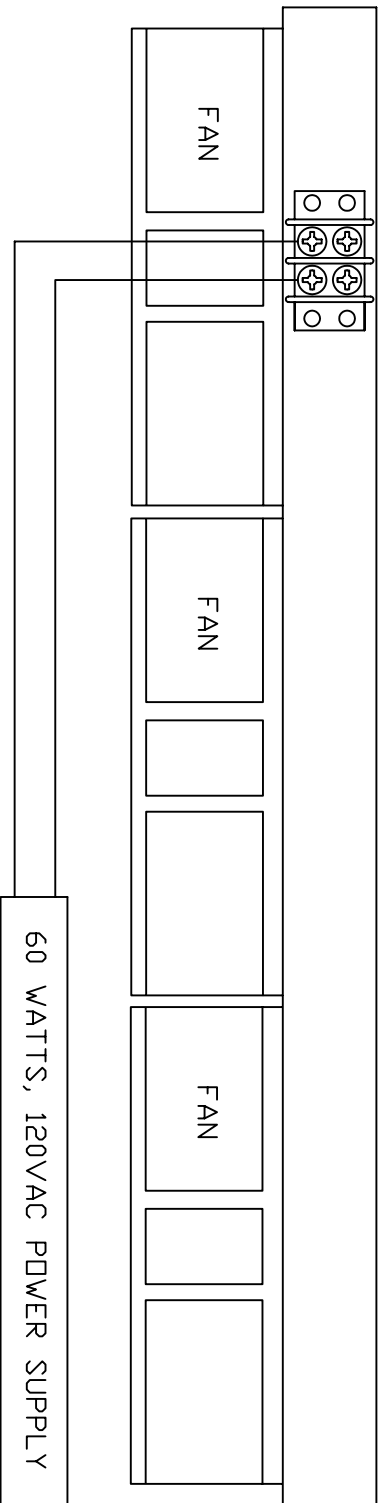

FAN WIRING DIAGRAMS 1200 AMPS

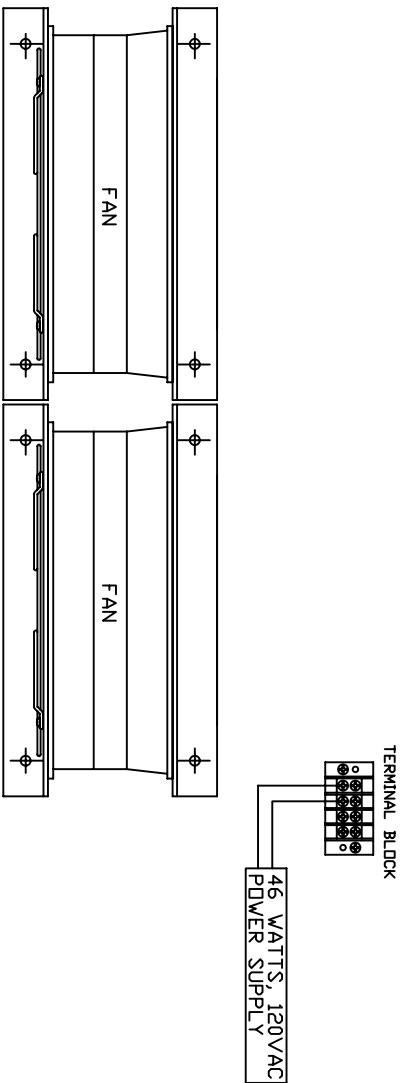
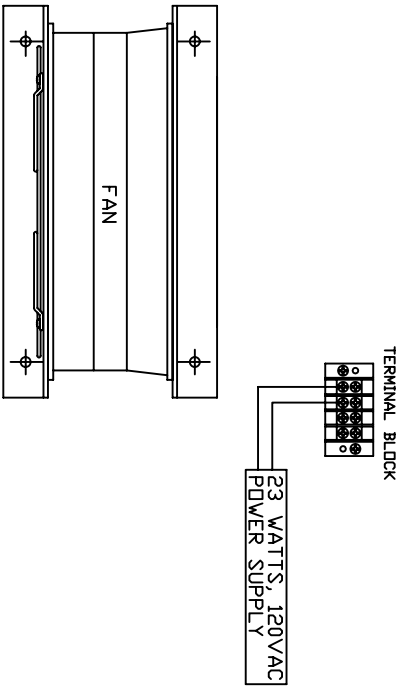

WARNING!
Fans **MUST** be ON when SCR power controller is on!
Power to fans must be applied before or coinciding with the turn on of line voltage to the SCR power controller. *Failure to do so will damage SCRs and other components.*

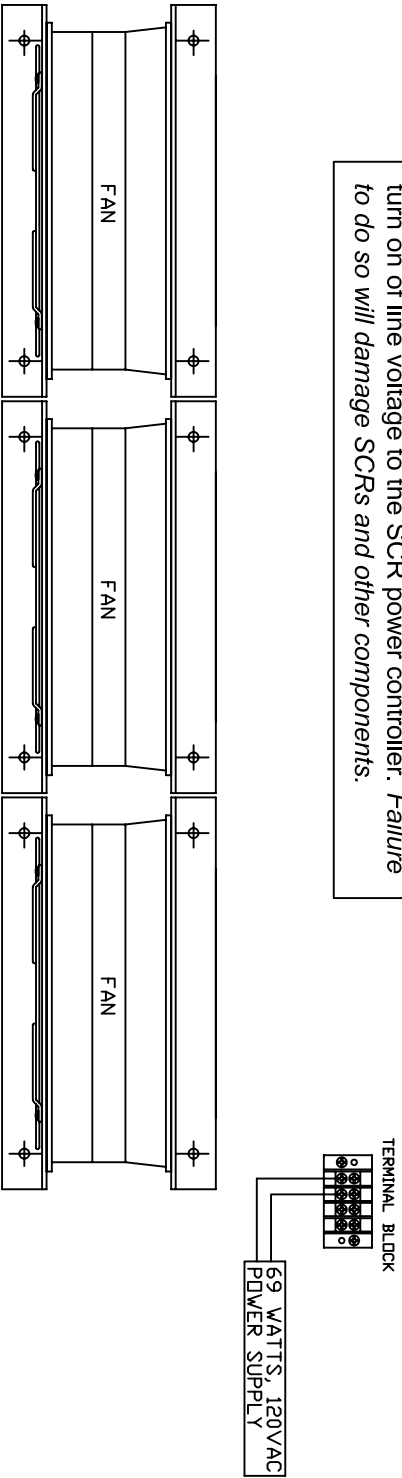

PHYSICAL DIMENSIONS

A6Z - 30 AMP

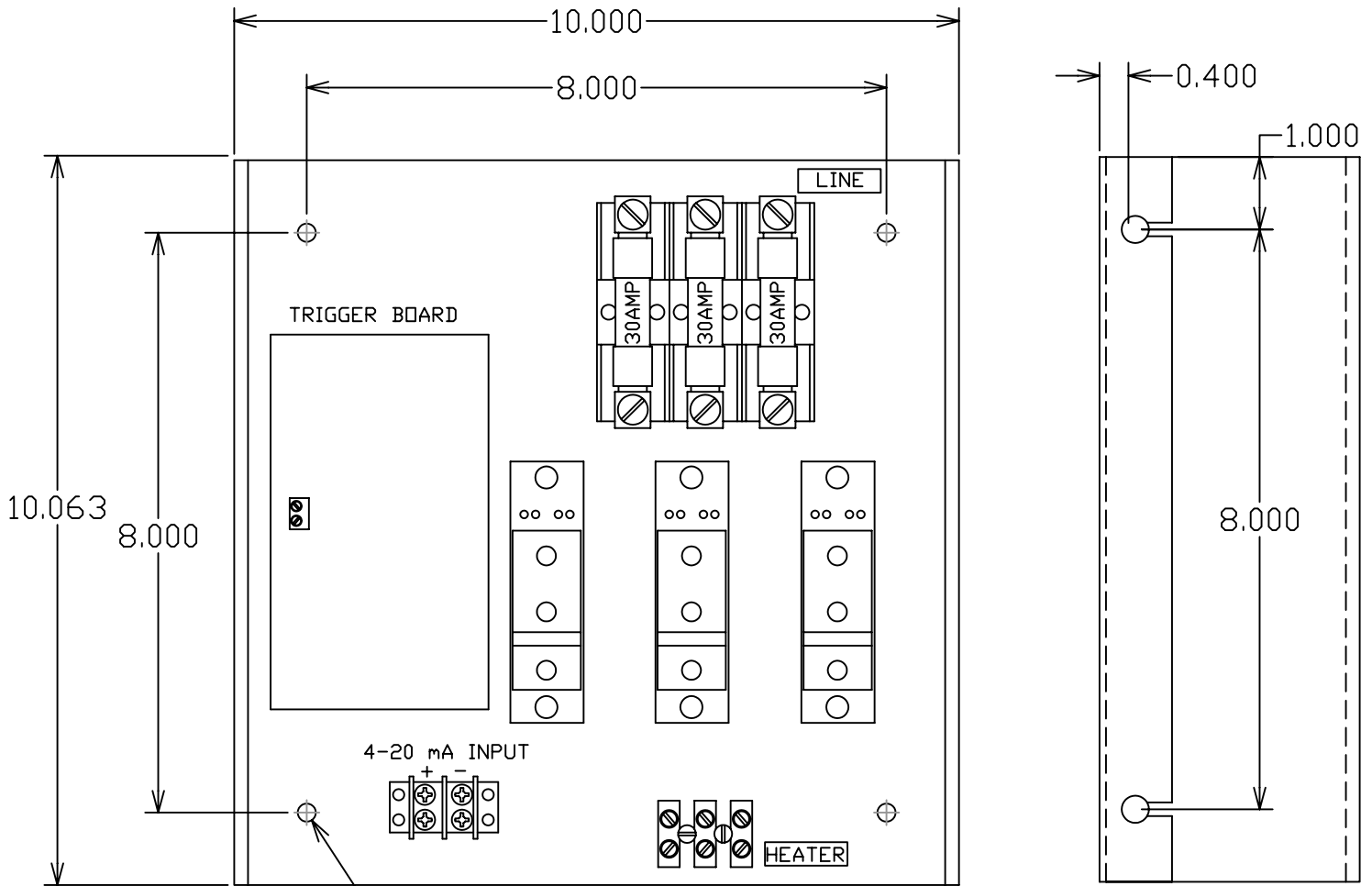

(4) MOUNTING HOLE DIAMETER 0.275"

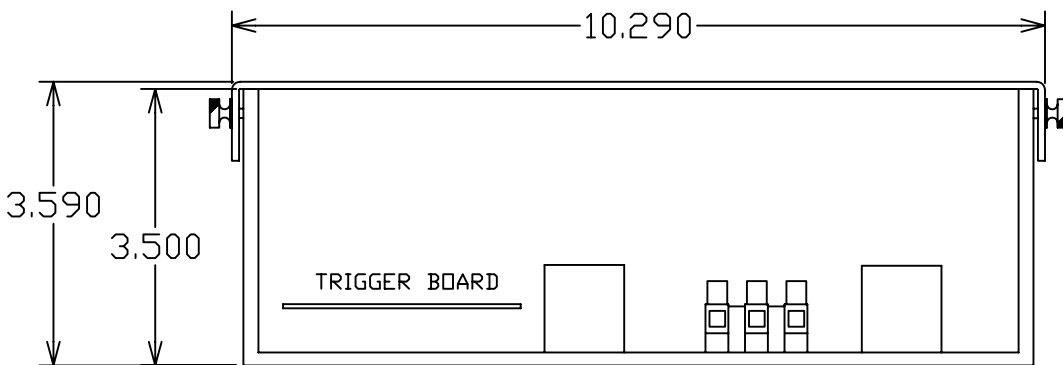

PHYSICAL DIMENSIONS

A6Z - 40, 60 & 80 AMP

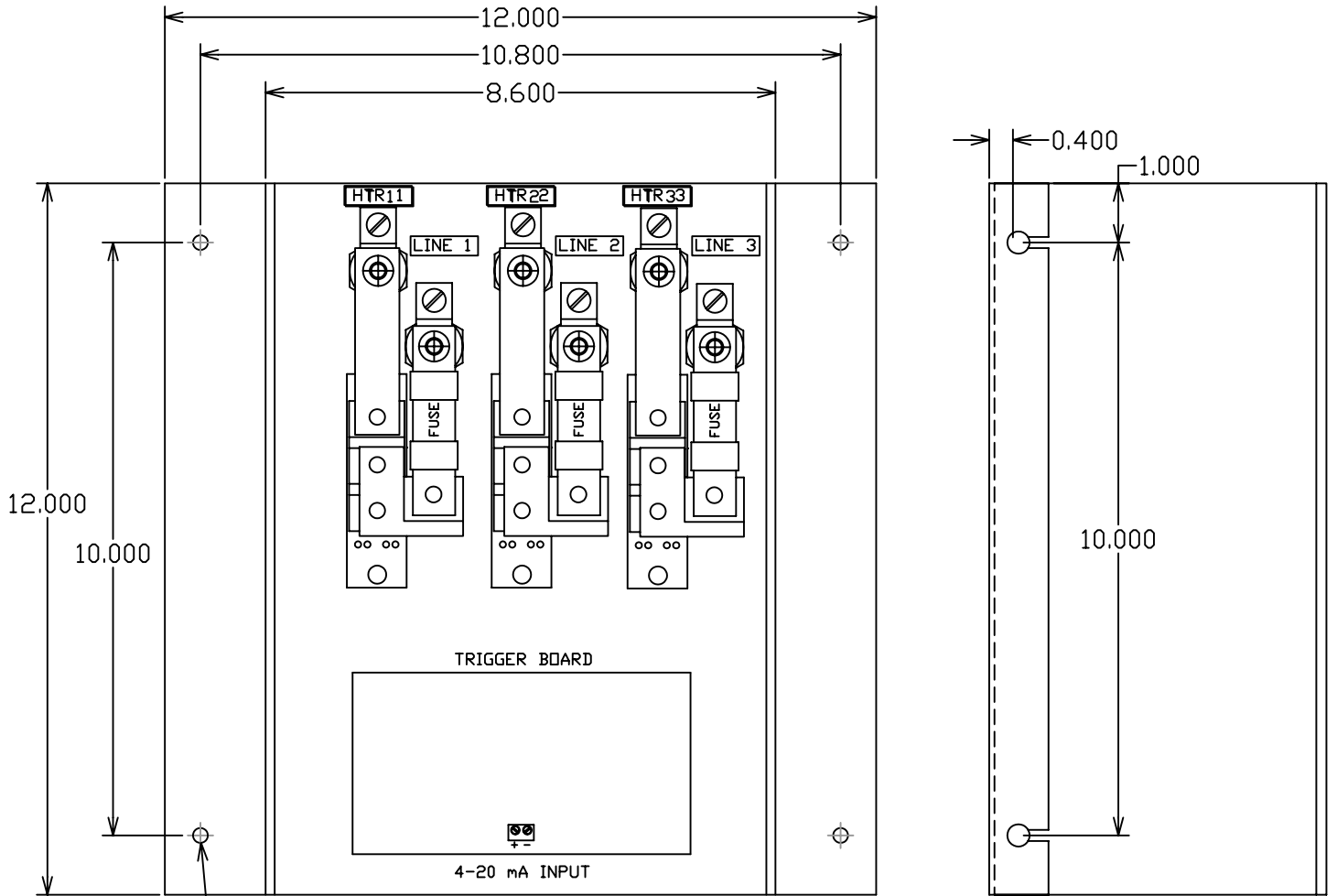

(4) MOUNTING HOLE DIAMETER 0.275"

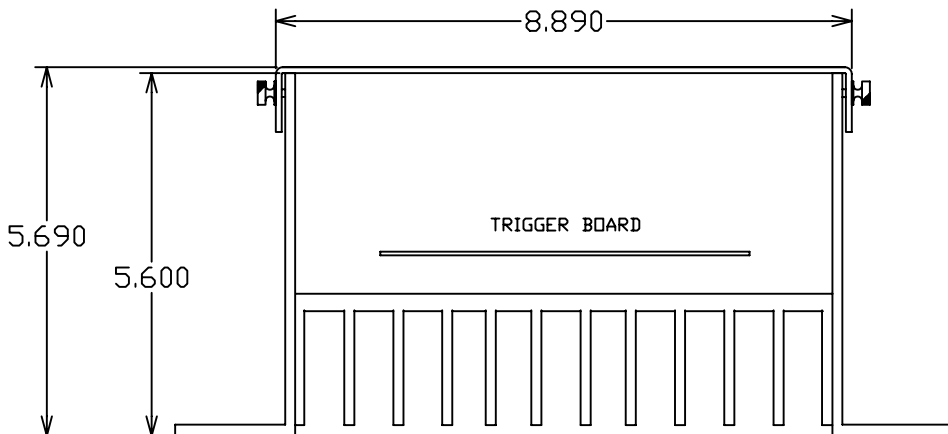

PHYSICAL DIMENSIONS

A6Z - 100 AMP

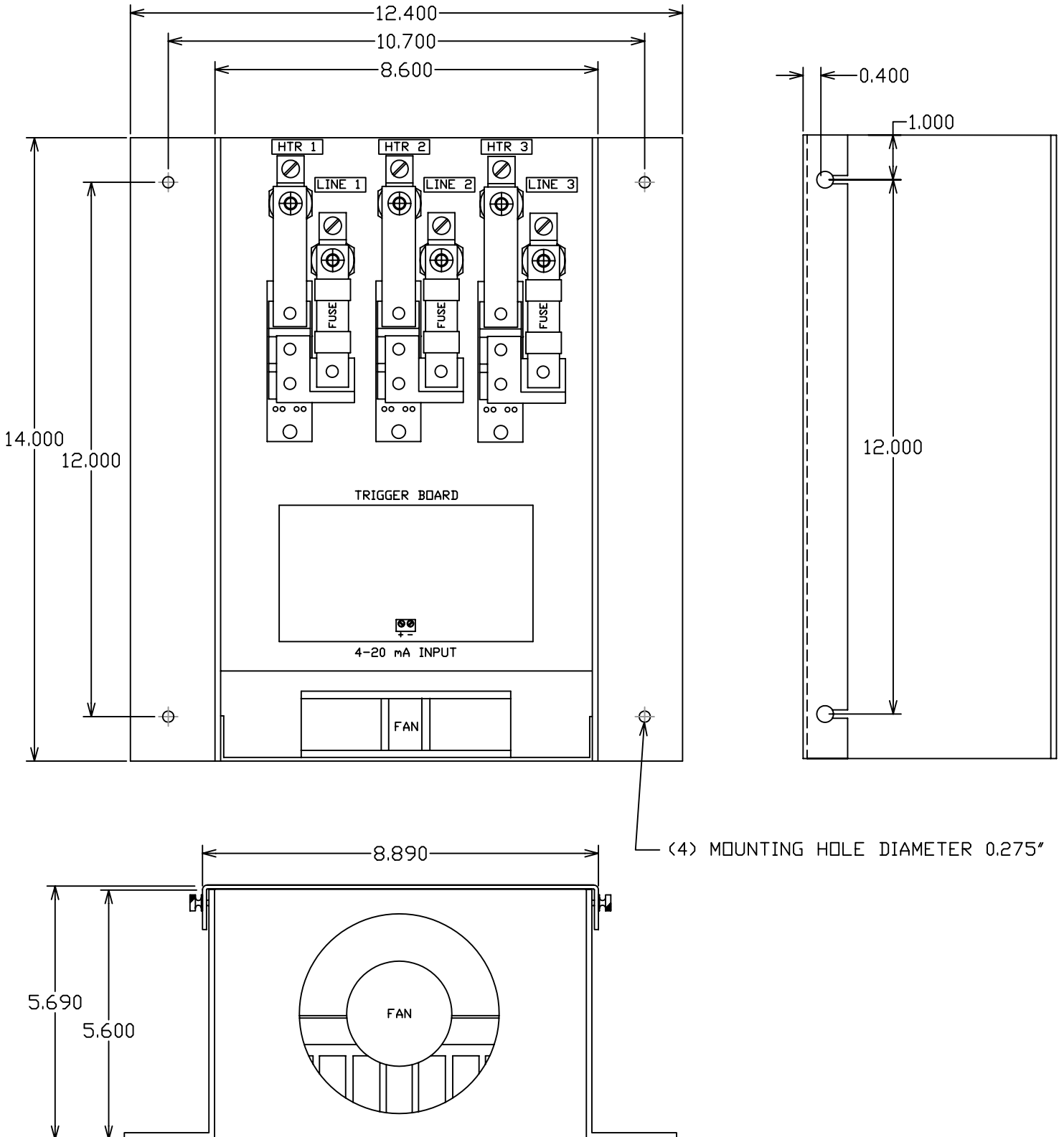

PHYSICAL DIMENSIONS

A6Z - 40, 60, 80 & 100 AMP THROUGH-HOLE MOUNTING (-TH)

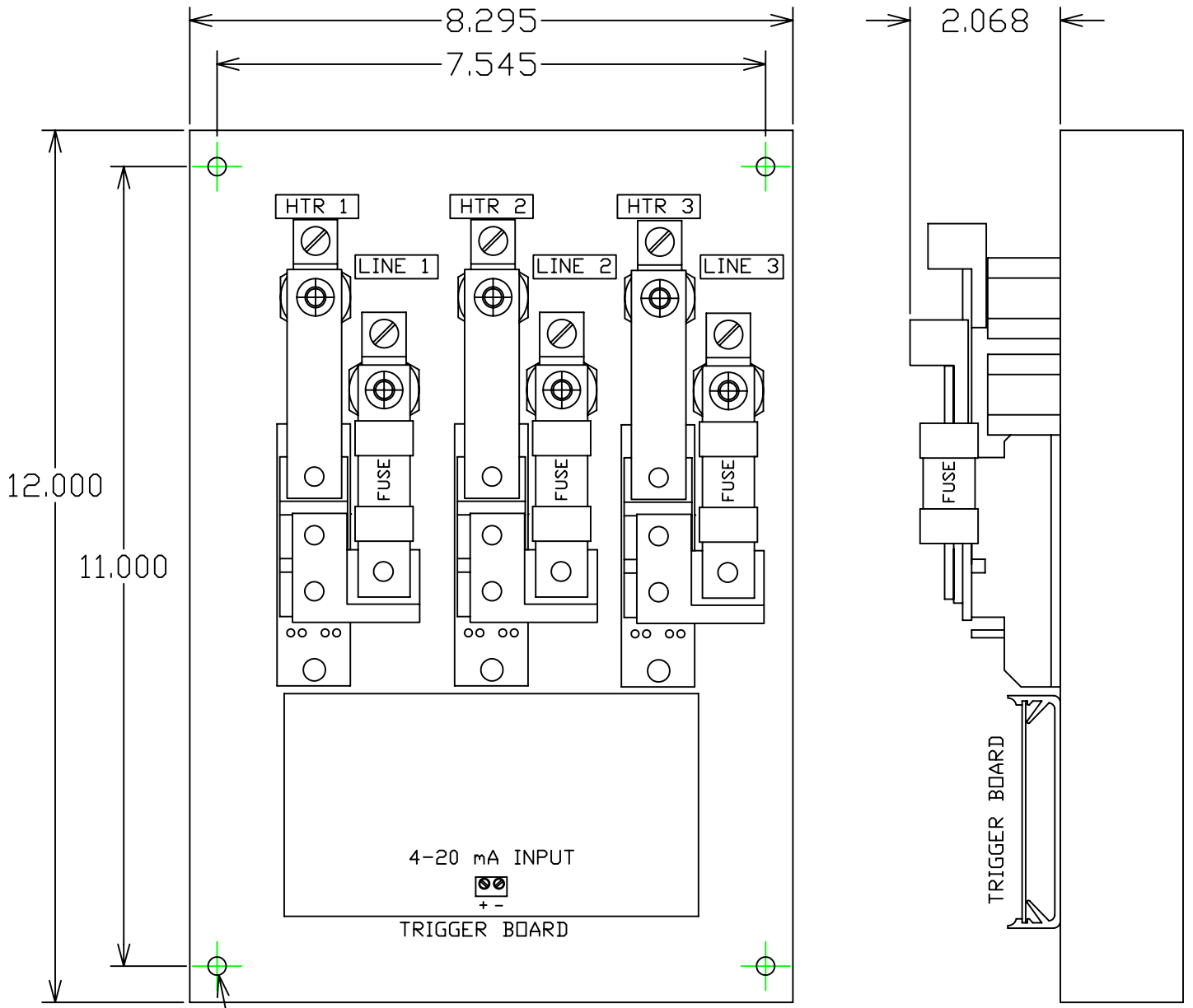

(4) 1/4"x20 TAPPED MOUNTING HOLE

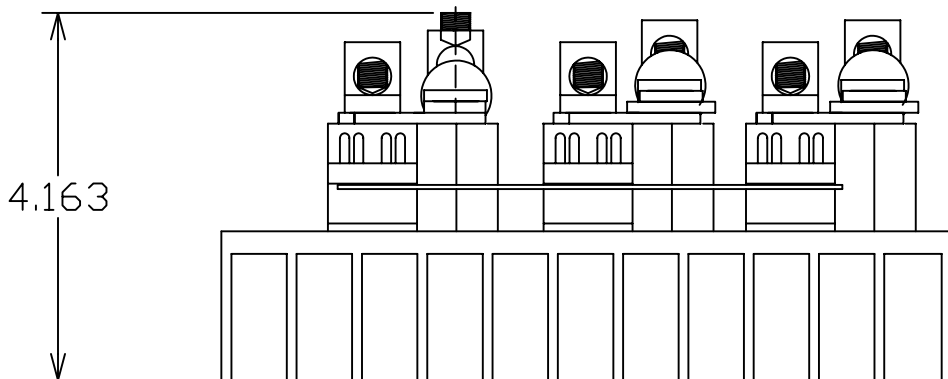

PHYSICAL DIMENSIONS

A6Z - 150 AMP- COMPACT (-C)

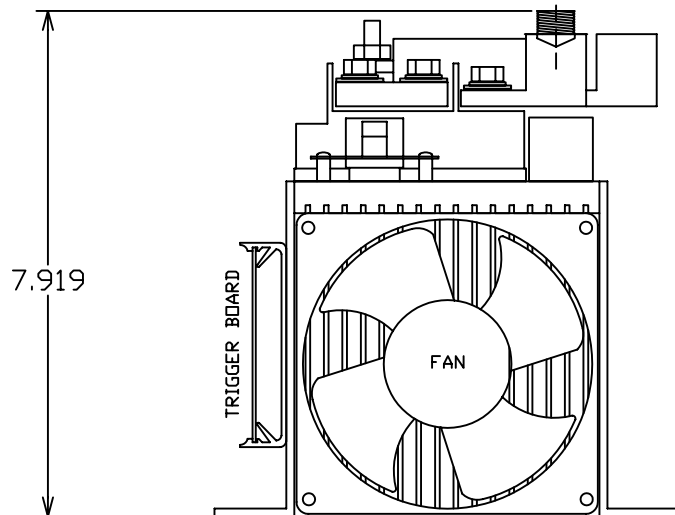
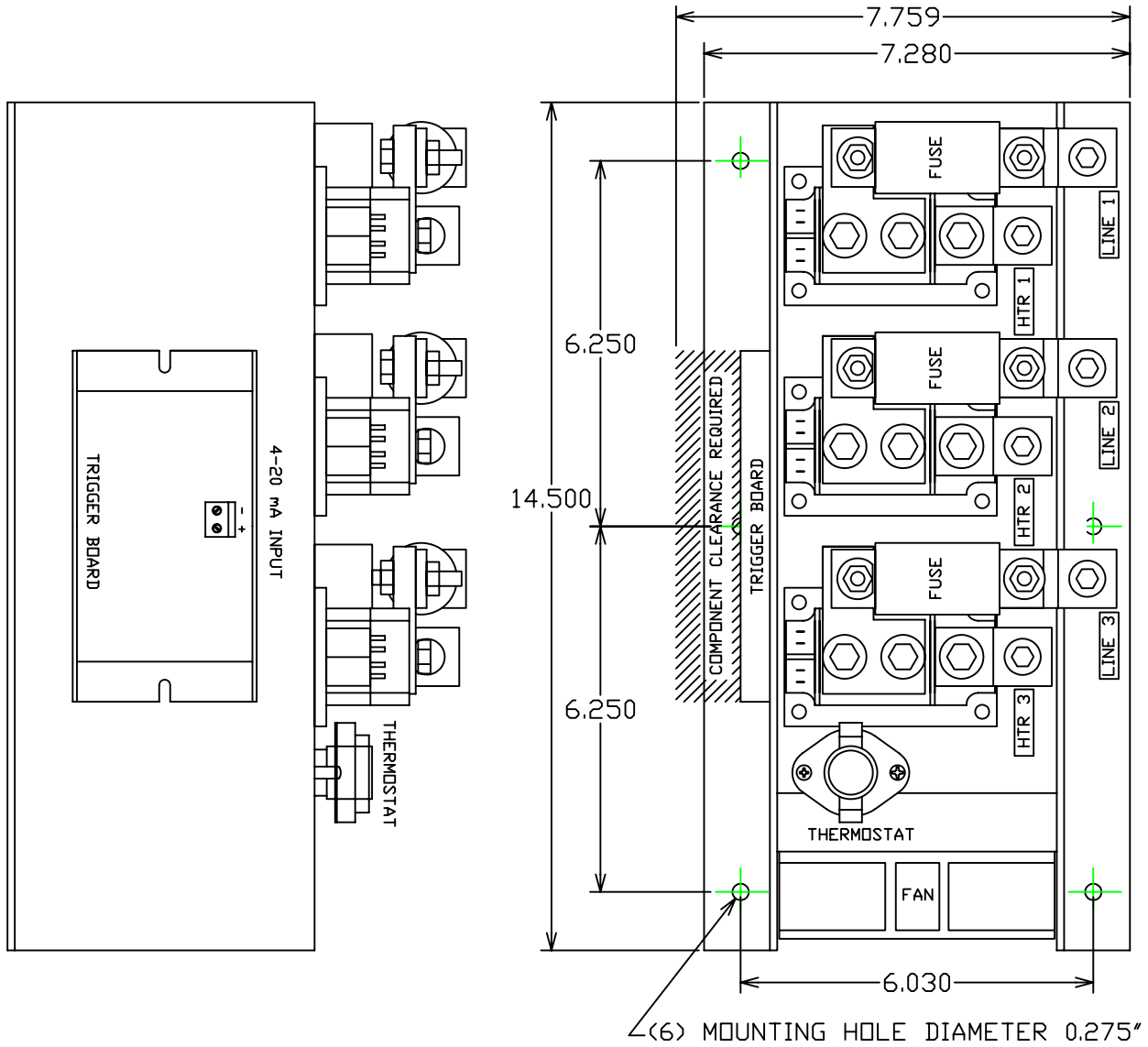

PHYSICAL DIMENSIONS

A6Z - 150, 200, 225 & 250 AMP

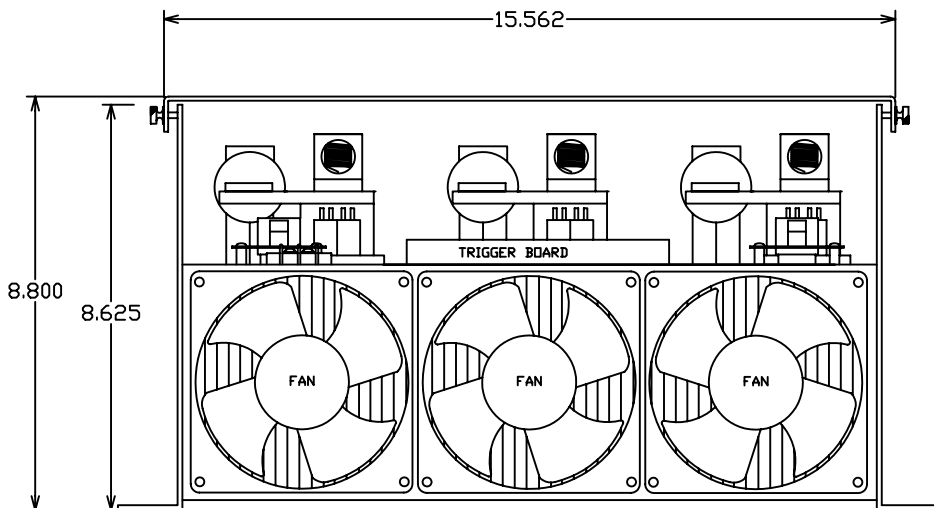
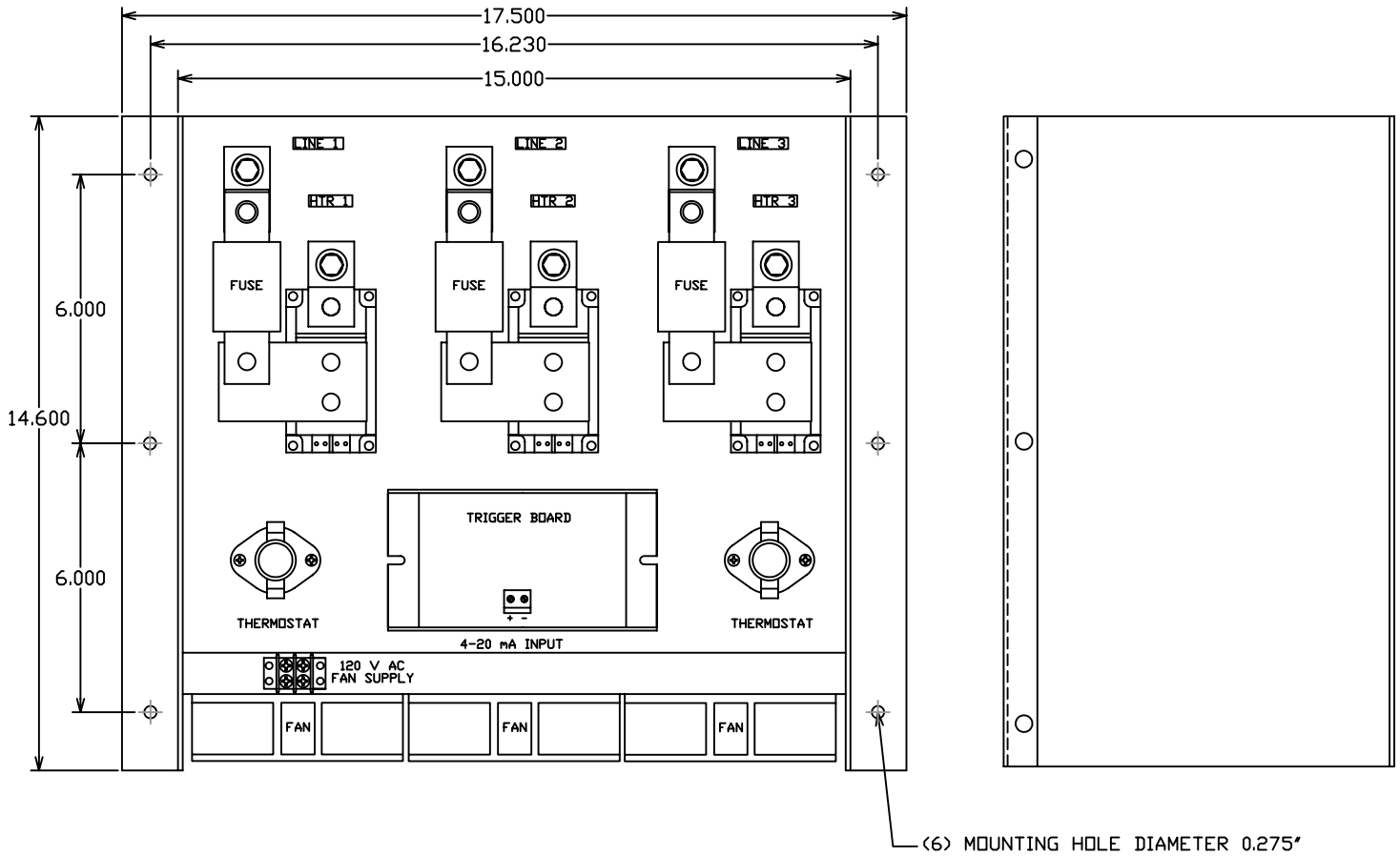

PHYSICAL DIMENSIONS

A6Z - 350 AMP

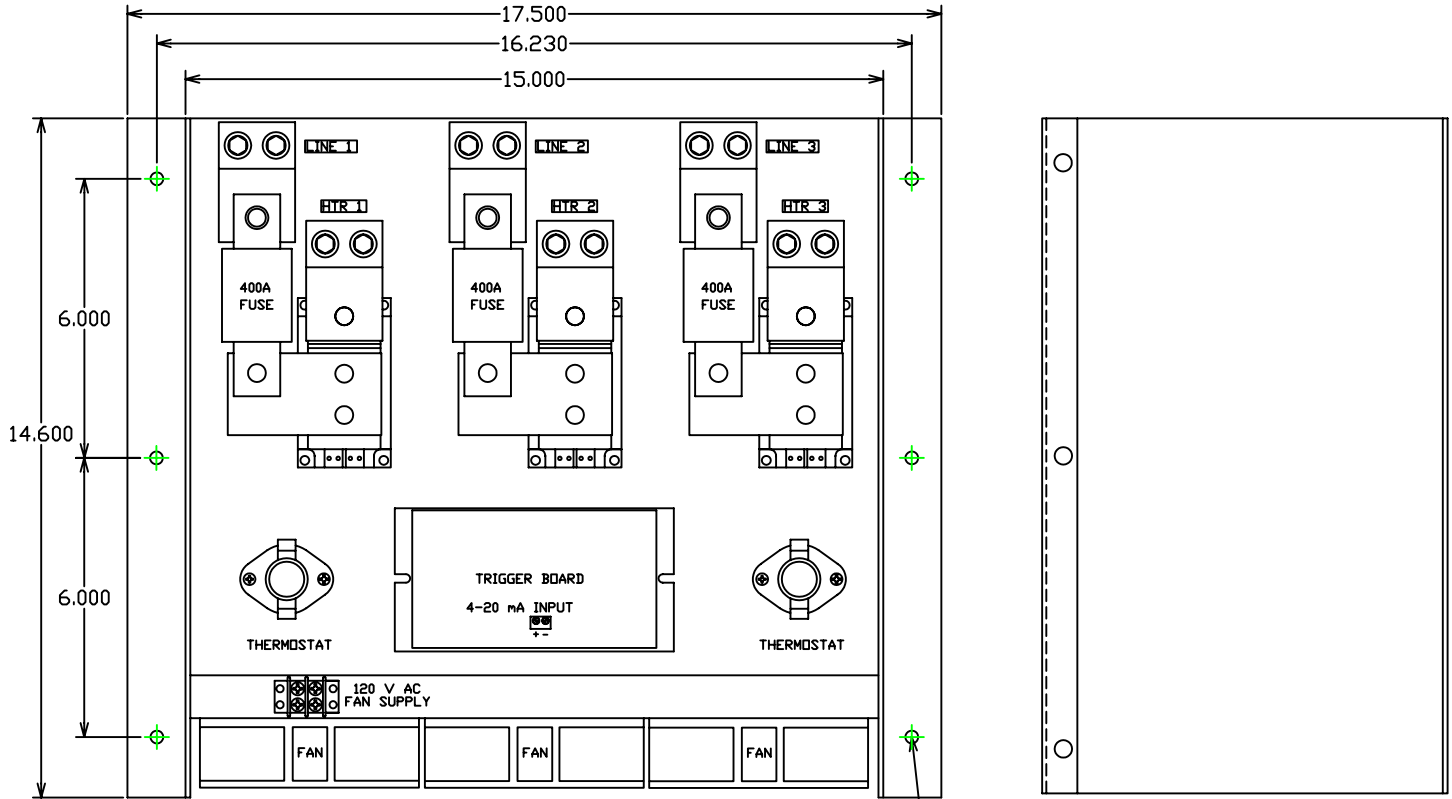

(6) MOUNTING HOLE DIAMETER 0.275"

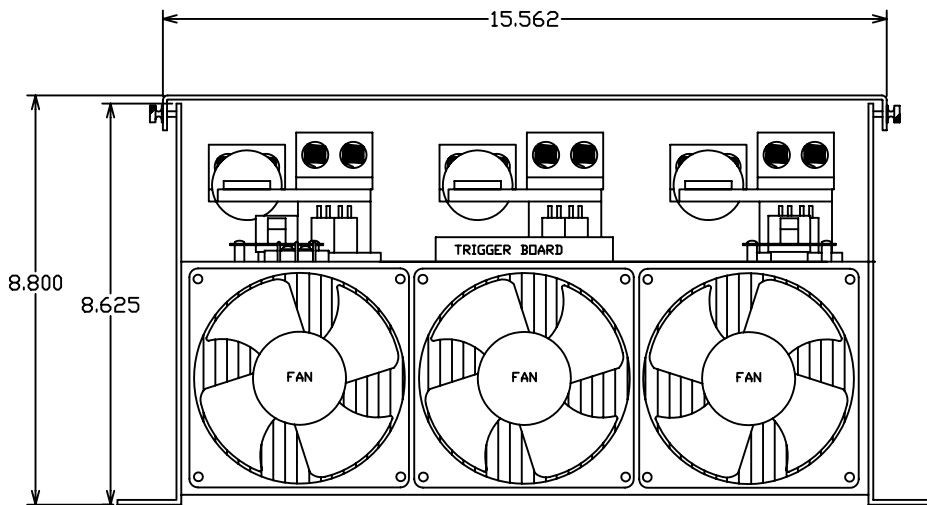

PHYSICAL DIMENSIONS

A6Z - 600 AMP

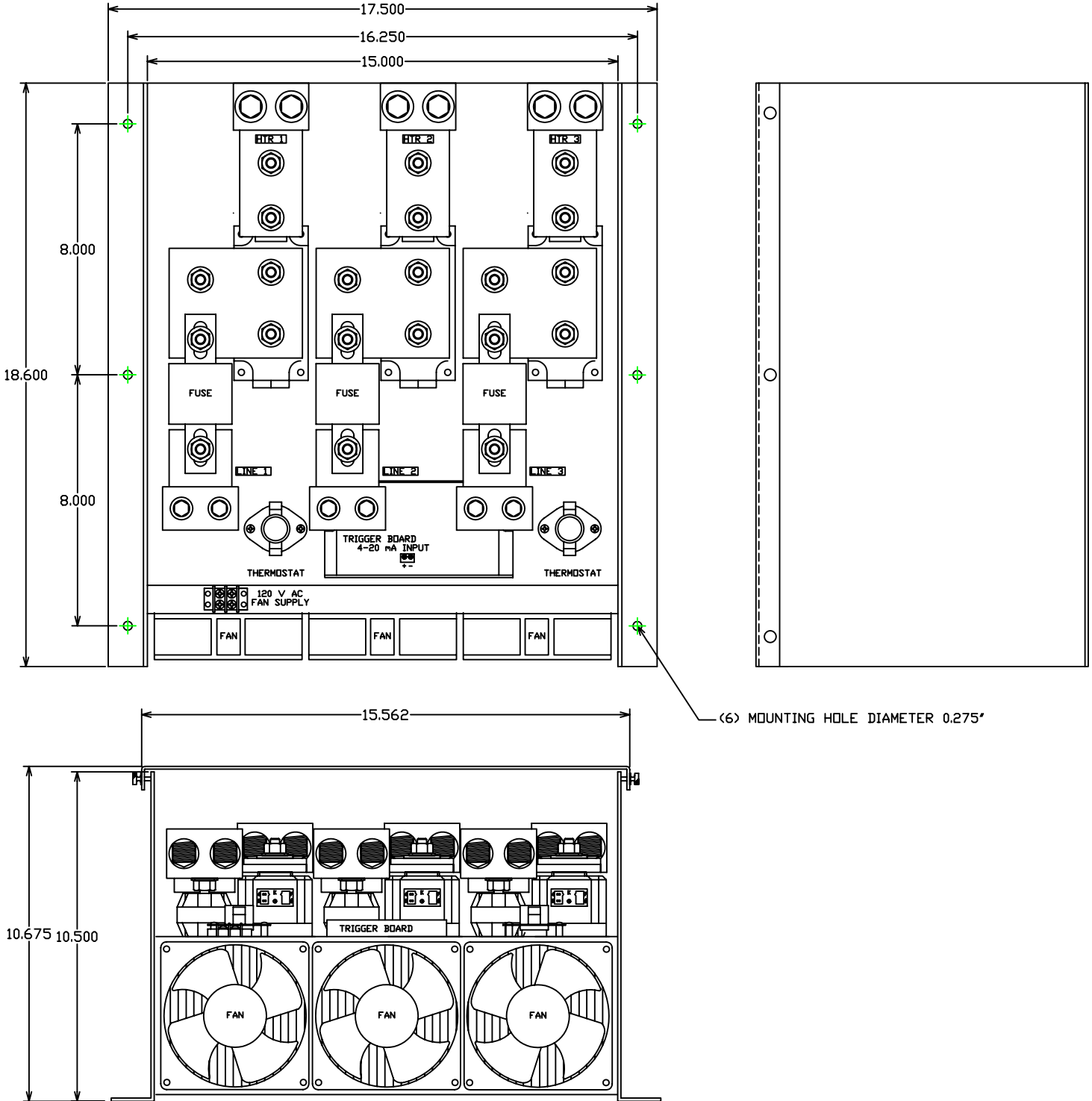

PHYSICAL DIMENSIONS

AGZ - 1200 AMP

